

0 - 10 V DIMMING DRIVER WIRING DIAGRAM
 Product Code A: 0-10V Dimmable + EM Backup on the product spec sheet

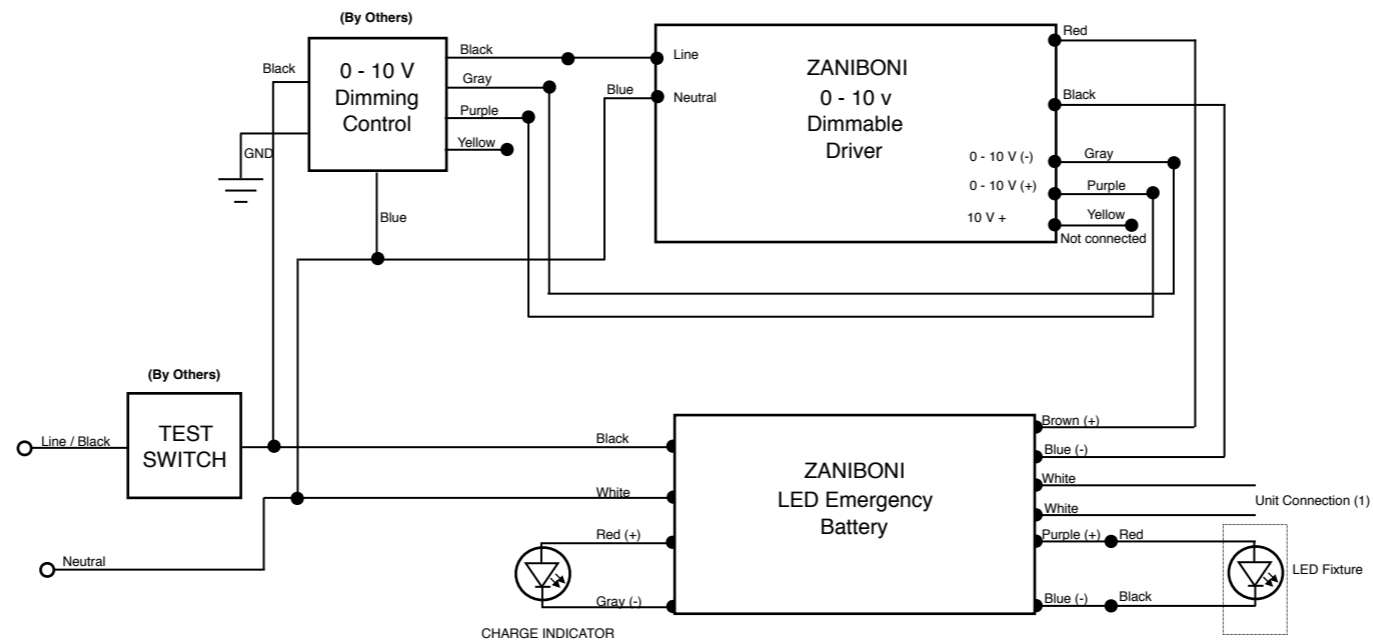

(1) DO NOT CONNECT UNTIL INSTALLATION IS COMPLETE AND AC POWER IS SUPPLIED

DRIVER AND SWITCH ILLUSTRATED IS FOR EXAMPLE PURPOSES ONLY - MANUFACTURERS VARY DEPENDING ON TECHNICAL REQUIREMENTS OF THE LIGHT