

Wiring Diagram I LED Emergency Equipment Backup Battery

12Vdc up to 48Vdc, Preset Current Dip Switched, 8W & 25W Max

Battery Info: 2500 mAh

Max Connected LOAD: 670 mA, 8W & 1000 mA, 25W

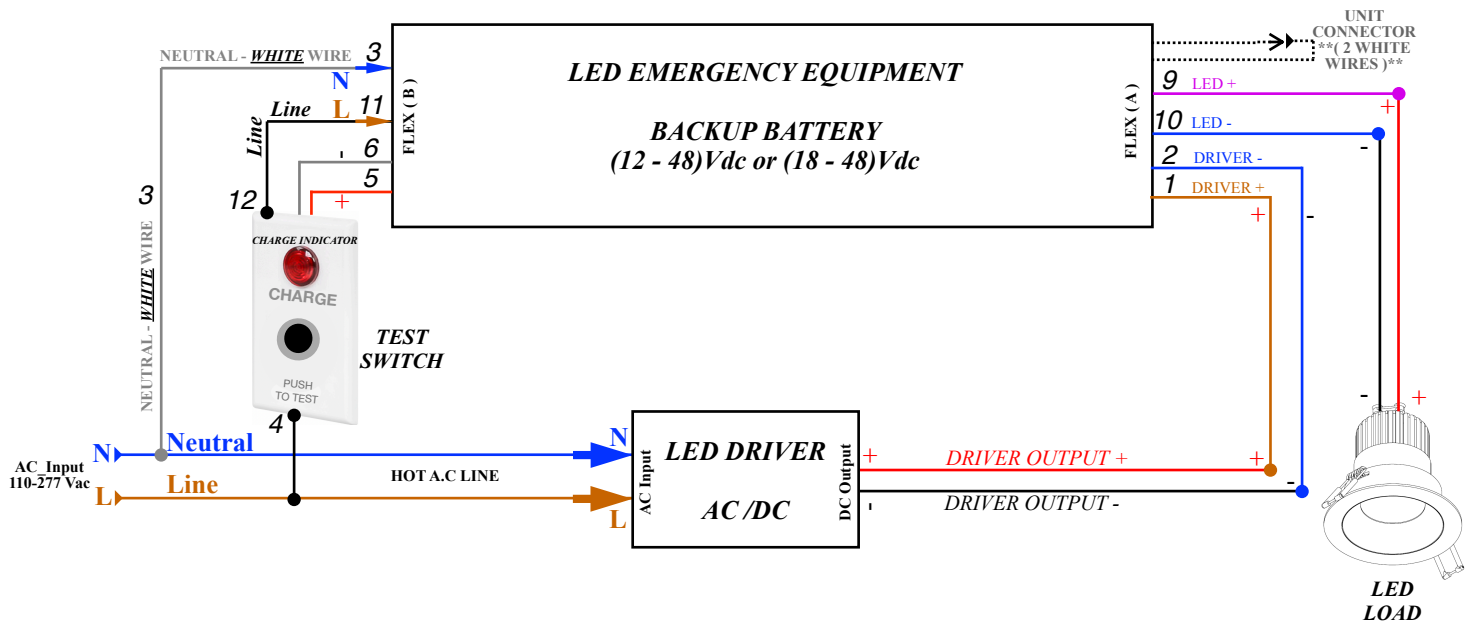

Illustration is for example purposes only. Components may vary depending on technical requirements of the light.

101 North Garden Avenue • Clearwater, Florida 33755 USA • P 727.213.0410 • Support@ZaniboniLighting.com

The manufacturer reserves the right to change or modify the design, dimensions and specifications at any time without notice. The manufacturer accepts no liability for consequential damage which is occasioned to the user based on the data provided.

For more information contact your representative or go to ZaniboniLighting.com.