

LUTRON PHASE DIMMING DRIVER WIRING DIAGRAM
 Product Code U: LUTRON Phase Dimmable + EM Backup on the product spec sheet

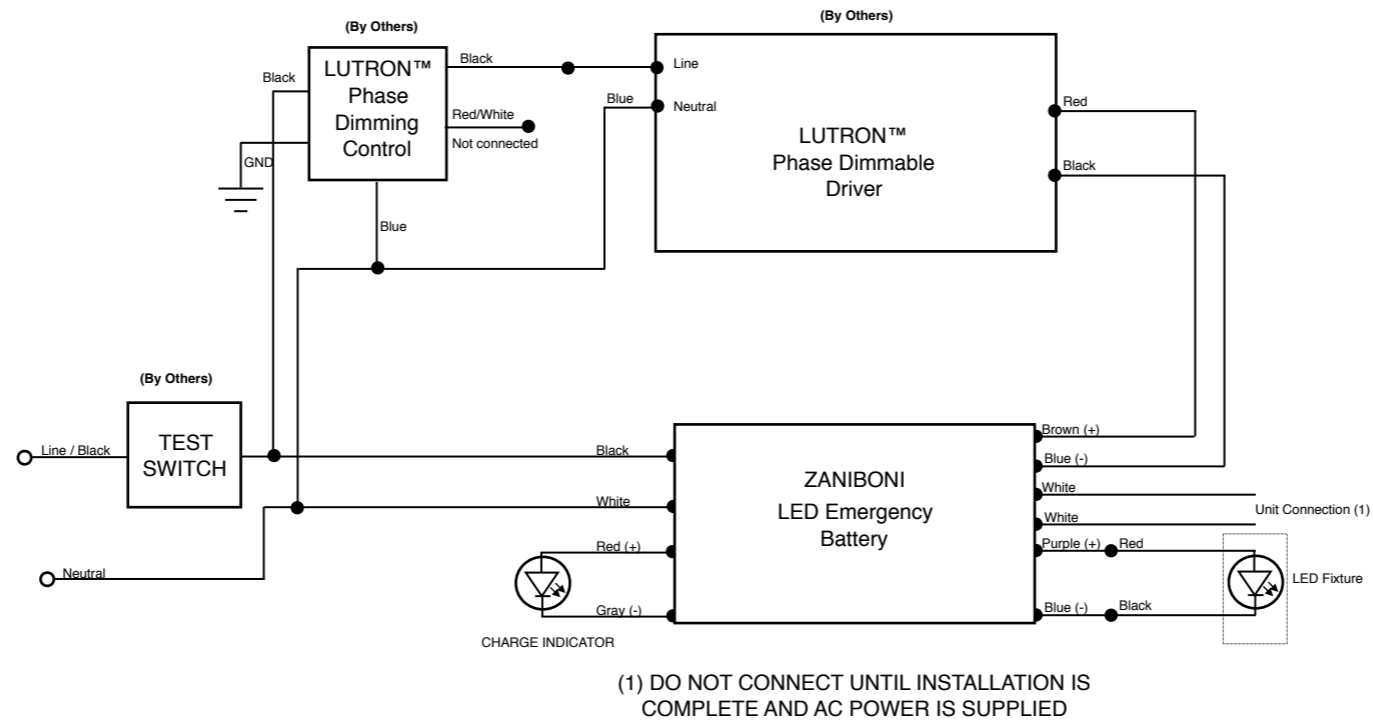

DRIVER AND SWITCH ILLUSTRATED IS FOR EXAMPLE PURPOSES ONLY - MANUFACTURERS VARY DEPENDING ON TECHNICAL REQUIREMENTS OF THE LIGHT